



FIRST® LEGO® League Challenge is the result of an exciting alliance between FIRST® and the LEGO® Group.



---

The purpose of this manual is to provide an overview of the basic framework necessary to prepare and deliver an official *FIRST*® LEGO® League Challenge in-person tournament.

## DEFINITION OF TERMS:

**Program Delivery Organization (PDO):** the organization contracted by *FIRST*® or LEGO® Education to offer the *FIRST* LEGO League program in a specific geographic location.

**Program Delivery Partner (PDP/partner):** the person or persons appointed by the PDO to manage and deliver the *FIRST* LEGO League program, including all official tournaments, in the specific geographic location.

**Tournament director:** oversees all aspects of the tournament and reports to the region's *FIRST* LEGO League PDP. This manual does not supersede that responsibility. The tournament director should plan according to the PDP's policies and procedures and communicate regularly with the partner.

**Key volunteer:** assumes a leadership role at the tournament as determined by tournament director. Key volunteers require advanced training as prescribed by *FIRST* headquarters.

**Judge advisor:** oversees the judging process and judging quality for the event, rather than judge teams. Ensures that *FIRST* LEGO League Challenge standards for judging and awards are followed and that *FIRST* LEGO League event rubrics are used. Responsible for overseeing all judges for the event, including any necessary pre-event communication and training. Ensures paperwork is provided for the judges (including rubrics, session flowchart, judge questions, session script, and awards list) for each judging pod. Being a judge advisor requires familiarity with the advancement policy and training to use the Official Judging Spreadsheet.

**Lead judge:** oversees their judging pod's team of judges and the timekeeping, completion of the judging rubrics, and handover of completed rubrics to tournament event staff. Welcomes team to the session. Interviews and observes teams. Supports the judge advisor in selecting team awards by contributing to the deliberation process and by writing short awards scripts extolling merits of winning teams. Serves as a mentor and role model for the team members and newer judges. Assists with closing ceremony in recognition of and award presentations to the teams.

**Judge:** interviews and observes teams together with other judges in the same judging pod using the *FIRST* LEGO League Challenge event rubrics. Serves as a mentor and role model for the team members, motivating them with useful feedback. Participates in deliberation process and as needed, in writing short awards scripts extolling merits of winning teams. Assists with closing ceremony in recognition of and award presentations to the teams.

**Judging pods:** previously called judging rooms, judging lanes, or judging sessions.

**Head referee:** helps recruit, train, and oversee all tournament referees. Has comprehensive knowledge of the season field setup, missions, rules, and challenge updates. Responsible for tracking and timing Robot Game rounds and coordinating referees with the master of ceremonies, scorekeeper, and field manager. Performs quality assurance on tournament challenge sets as well as all competition and practice fields in advance of the event. Provides scores to the judge advisor for final judging deliberations.

**Referee:** observes team Robot Game matches, identifies rule violations, assesses field for scoring of matches, and participates in deliberations regarding contested calls and official scores. Requires advance training on season's game, including field setup, rules, and missions. Plays a critical role in ensuring smooth flow of match play and maintaining the pace of the event. Embodies *FIRST* Core Values while monitoring and promoting sage practices on and around the playing field.

**Technical advisor:** works closely with tournament director. Oversees DJ, audio, visual, lighting, and computer and software needs from setup to teardown. Ensures technical systems are functional, safe, and meet event needs. Understands the hardware needs for the software used for scoring and/or display. Is the go-to person for tournament staff if computer problems arise.

**Master of ceremonies (emcee):** responsible for setting the tone of the competition. Creates and sustains an exciting, fun atmosphere throughout the event; embodies the spirit of *FIRST*; and is the consummate *FIRST* ambassador. Ensures the smooth flow of match play, maintains the pace of the event, and can significantly impact the quality of the competition.

**Teams coordinator:** coordinates communications with teams. Often oversees team check-in and/or pit administration. Produces event-related team materials including team registration packets. Works closely with the tournament director and is the point of contact for special-needs requests.

**Team Pit Area:** serves as the teams' home base during the event. The pit admin is located in this area and serves as an information point.

**Volunteer coordinator:** is responsible for the onsite management of event-day volunteers, including setting up registration for volunteers, managing any walk-on volunteers, and problem-solving. They work closely with the tournament director and venue on all volunteer logistics, including pre-event planning and communication. Please note, this is a key position that involves a large amount of work in advance of the event; individuals should only sign up for this role if directed to do so by a *FIRST* LEGO League operational partner or *FIRST* LEGO League tournament director.

1. <i>FIRST</i> , <sup>®</sup> the LEGO Group, and <i>FIRST</i> <sup>®</sup> LEGO <sup>®</sup> League Challenge .....	4	Event Safety, Accessibility, and Cancellation .....	22
For Inspiration and Recognition of Science and Technology ( <i>FIRST</i> ) .....	4	Emergency and Evacuation Plans .....	22
<i>FIRST</i> LEGO League.....	4	Safety .....	22
2. Leadership – Planning Team .....	6	Incidents.....	23
Roles for Managing All Challenge Tournaments .....	6	Accessibility .....	23
Resources for Planning Team Members .....	6	Cancellation Policy.....	23
3. In-Person Venue.....	7	10. Production .....	24
Seven Primary Areas .....	7	Production Overview.....	24
Other Site Considerations .....	13	Production: Robot Game.....	24
Space Summary .....	13	Production: Robot Game Technical Elements.....	25
4. Preparation Timeline .....	14	Production: Robot Game without Cameras .....	25
Early Key Decisions.....	14	Production: Ceremonies .....	25
Setting Up before the Tournament.....	14	11. Judging Overview .....	27
5. Budget .....	16	Judging Standards and Guidelines.....	27
The Budget.....	16	Judging Roles.....	28
Examples of Common Budget Items .....	16	Recruitment Tools .....	29
6. Teams and Communications.....	17	Training Tools .....	29
Check-In Packets.....	17	12. Robot Game Overview .....	30
What Teams Receive after the Event.....	17	Referee Standards and Guidelines.....	30
General Data Protection Regulation (GDPR) .....	17	Training Tools .....	31
7. Scheduling .....	19	Robot Competition Area Setup.....	31
Preparing a Schedule .....	19	13. Event Promotion.....	33
8. Documents and Signage .....	21	Available Resource Materials .....	33
Documentation.....	21	14. Post Event .....	34
Sponsor Recognition.....	21	Survey.....	34
Parking and Entrance Signage.....	21	Returns .....	34
Area Signage .....	21	Thank Your Sponsors .....	34
9. ....			

This manual is intended to help you plan your resources and needs for your in-person event. Please adjust as your specific circumstances require.

### GLOBAL STANDARD



Marks an item that is a *FIRST* LEGO League Challenge Global Standard

### BEST PRACTICE



Marks an item that is a *FIRST* LEGO League Challenge Best Practice



### Your Feedback Matters

If you have feedback about this manual, please contact:

Kathy Vachon

[kvachon@firstinspires.org](mailto:kvachon@firstinspires.org)



## FIRST,<sup>®</sup> the LEGO Group, and FIRST<sup>®</sup> LEGO<sup>®</sup> League Challenge

**FIRST<sup>®</sup> (FOR INSPIRATION AND RECOGNITION OF SCIENCE AND TECHNOLOGY)**

Learn more about [FIRST<sup>®</sup>](#).

### FIRST<sup>®</sup> LEGO<sup>®</sup> LEAGUE

[FIRST<sup>®</sup> LEGO<sup>®</sup> League](#) was formed in 1998 as an alliance between FIRST and the LEGO Group. Guided by adult coaches, FIRST LEGO League Challenge teams research a real-world problem, such as food safety, recycling, or energy, and are challenged to develop a solution. They also must design, build, and program a robot using LEGO MINDSTORMS<sup>®</sup> technology and then compete on a tabletop playing field.

All participants in a FIRST LEGO League tournament are expected to demonstrate the Core Values of FIRST. We express the FIRST philosophies of *Gracious Professionalism<sup>®</sup>* and *Coopertition<sup>®</sup>* through our Core Values:

- Discovery: We explore new skills and ideas.
- Innovation: We use creativity and persistence to solve problems.
- Impact: We apply what we learn to improve our world.
- Inclusion: We respect each other and embrace our differences.
- Teamwork: We are stronger when we work together.
- Fun: We enjoy and celebrate what we do!

[Learn more](#) about the FIRST, FIRST LEGO League, and the LEGO Group relationship and history. After a child progresses through the FIRST LEGO League divisions, they are encouraged to move up to FIRST<sup>®</sup> Tech Challenge (Grades 7-12) and/or FIRST<sup>®</sup> Robotics Competition (Grades 9-12). Explore the full progression at [firstinspires.org](http://firstinspires.org).



# FIRST Progression of Programs

FIRST combines the rigor of STEM learning with the fun and excitement of traditional sports and the inspiration that comes from community through a progression of programs that have a proven impact on learning, interest, and skill-building inside and outside of the classroom.

GRADES PREK-8 · AGES 4-16\*



## FIRST LEGO LEAGUE

**Young Innovators Use Skills and Imagination to Solve Problems as a Team**

### THE CHALLENGE

Through a guided, global robotics program, students are introduced to STEM learning and exploration at an early age. Children can begin with Discover (ages 4-6) and progress through Explore (ages 6-10) and Challenge (ages 9-16\*), or join at any division based on their age or grade level.

### THE JOURNEY

Young children are introduced to STEM concepts and develop habits of learning through engaging, fun challenges and competitions using LEGO Education materials.

### THE OUTCOME

Students gain real-world problem-solving experiences that inspire them to experiment and grow their critical thinking, coding, and design skills while building confidence, growing their knowledge, and developing habits of learning.

\*Ages vary by division and country

GRADES 7-12 · AGES 12-18



## FIRST TECH CHALLENGE

**It's Way More Than Building Robots**

### THE CHALLENGE

Teams of students design, build, program, and operate robots powered by Android technology to compete head-to-head in an alliance format. Students are encouraged to create team brands and be an ambassador for FIRST and STEM in their communities.

### THE JOURNEY

Teams compete at local and regional events, qualifying up to the FIRST Championship. They earn awards based on their teamwork, creativity, innovation, and the engineering design process.

### THE OUTCOME

While developing their STEM skills and mastering engineering principles, students learn the value of persistence, innovation, teamwork, and the engineering design process. High school students are eligible to apply for more than \$80 million in scholarships from colleges, universities, and technical programs.

GRADES 9-12 · AGES 14-18



## FIRST ROBOTICS COMPETITION

**An Exciting Sport Built Around the World of STEM**

### THE CHALLENGE

Under strict rules, with limited time and resources, high school teams use sophisticated technology to build and program industrial-size robots for a challenging field game. Each team develops a brand, raises funds to meet its goals, and works to promote STEM in the local community.

### THE JOURNEY

At district and regional events, cheering crowds root for qualifying teams as students compete with their robots for prestigious awards and a coveted spot at the FIRST Championship.

### THE OUTCOME

As students learn real-world engineering concepts, they build their confidence and workforce skills and connect with professional team mentors and sponsors who can help them succeed. Plus, they can apply for more than \$80 million in college, university, and technical program scholarships.



At the heart of FIRST are its Core Values, which emphasize the contributions of others, friendly sportsmanship, teamwork, learning, and community involvement. These include: *Gracious Professionalism*® – Respect for others, being a good sport, and sharing what you learn. *Coopertition*® – Competing hard, but also helping the other teams. [www.firstinspires.org](http://www.firstinspires.org)

## Leadership – Planning Team



### ROLES FOR MANAGING ALL CHALLENGE TOURNAMENTS

#### Primary Roles *Required*

- Tournament Director
- Head Referee
- Judge Advisor
- Volunteer Coordinator

#### Secondary Roles *Recommended but not required*

- Teams Coordinator
- Technical Advisor
- Materials Coordinator
- Production Manager
- Food Coordinator
- Facilities Coordinator

#### Optional Roles *Not required*

- Fundraising Coordinator
- Media Coordinator

### RESOURCES FOR PLANNING TEAM MEMBERS

- Former *FIRST* LEGO League participants
- Staff of other *FIRST* LEGO League tournaments
- Established *FIRST* coaches with no relationship to any team participating in the event
- Employees of tournament sponsors
- Friends or coworkers
- Elementary and middle school teachers
- Engineering and science students (from your local universities)
- Elementary Education majors (from your local universities)
- Local STEM action groups
- Parents of competition teams not participating at the current event
- Older *FIRST* participants



## In-Person Venue

### SEVEN PRIMARY AREAS

Every FIRST LEGO League tournament should have these areas.



### I. Opening and Closing Ceremonies Area

Possibly video



A stage or podium for speakers.

----->  
Space for parade of teams for the Opening and a high-five line for the Closing Ceremonies.

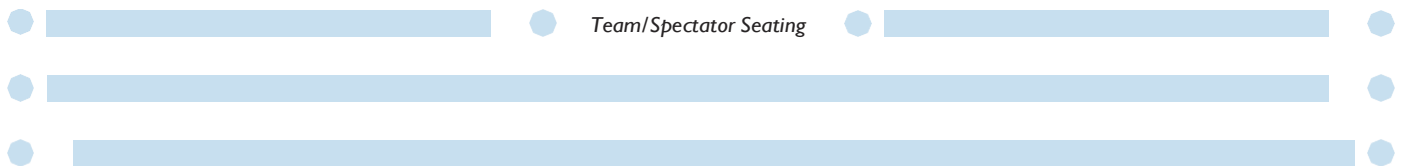

### SUPPLIES AND EQUIPMENT

OPENING CEREMONY	CLOSING CEREMONY
Access to electricity	Podium or other staging for speaker
Ample seating for spectators	Audio/visual support
Built-in audio and video capacities	Space for teams to receive awards
National flag and national anthem recording or performer (per local protocol)	

## 2. Robot Competition Area 🌟

This area often doubles as the Opening and Closing Ceremonies Area. [See Chapter 12 for more details.](#)

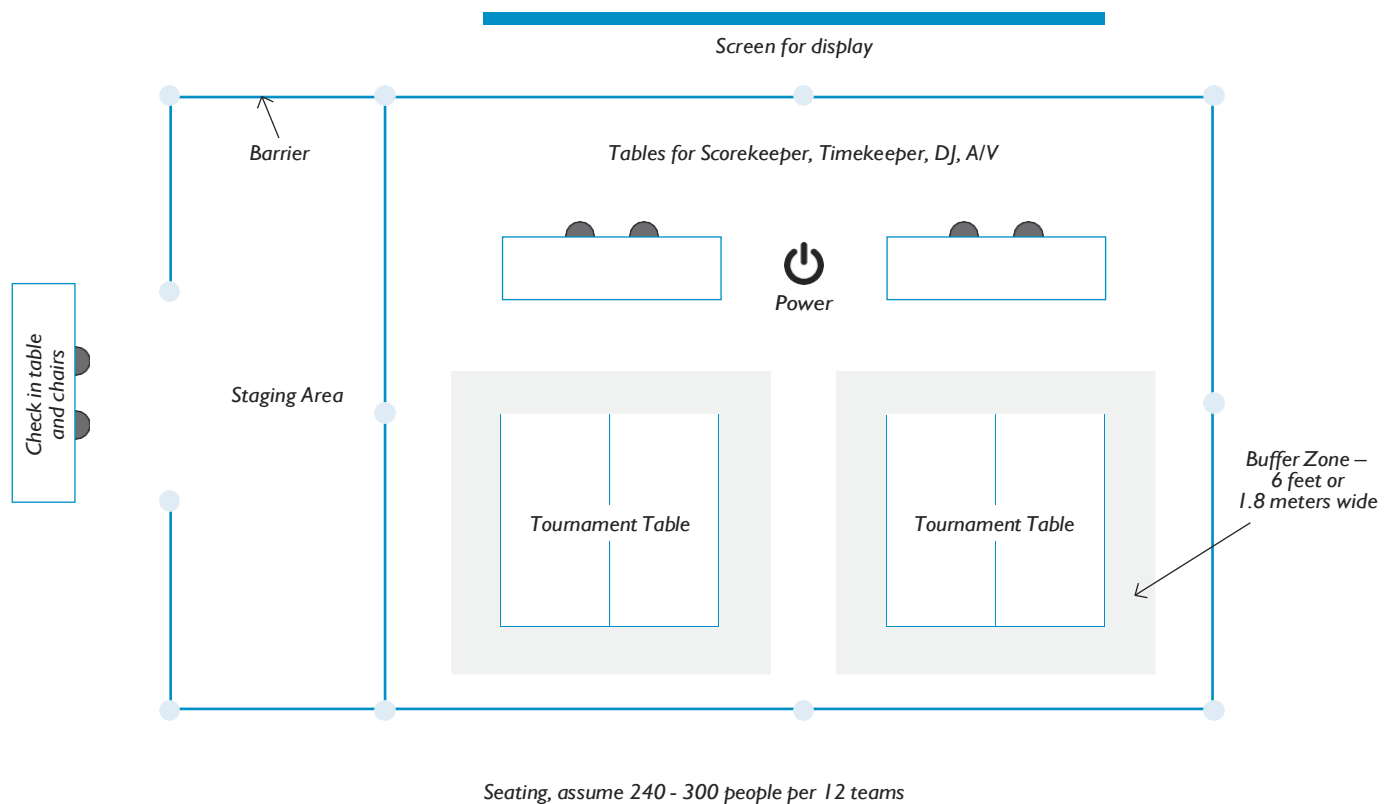

### SUPPLIES AND EQUIPMENT - MUST HAVE ITEMS

ROBOT GAME - MUST HAVE ITEM		
ITEM	DESCRIPTION	QUANTITY
Tournament setup	One tournament setup = two 4' x 8' competition tables together	1 per 12 teams
Table supports: legs, folding tables, saw horses, or milk crates	To support the competition tables (must support six corners for each tournament setup and four corners for each solo practice competition table)	Varies
Wood screws	To hold competition tables together	2 per tournament setup
Challenge sets	Challenge field with mat, LEGO mission models, and extra Dual Lock	2 per tournament setup
Clipboards, scoresheets, and scoring materials	<p>Clipboards: two per tournament setup plus one for head referee and one for emcee.</p> <p>Blank scoresheets: one per practice or official round (at least three) per team (i.e., # Scoresheets = # Teams x # Rounds). It is helpful to have a few extra blank scoresheets.</p> <p>Pens or pencils: at least one per referee</p> <p>Tablets/phones (for electronic scoring): two per tournament setup plus one for head referee; one may be useful for emcee</p>	See description.
Timer/stopwatch	To measure time remaining in each match (can be projected using scoring software or measured at each table by a stopwatch or cell phone timer)	1 overall or 1 per tournament setup
Small signs, if more than one tournament setup	To identify tournament setup for audience and teams (may be letter-size signs or colored table skirts that match the table names on the schedule)	2 per tournament setup



**SCOREKEEPING – MUST HAVE ITEM**

ITEM	DESCRIPTION	QUANTITY
Computer	For scoring and audio/visual needs	1 or more
Extension cords and power strips	For scoring, audio/visual, and video camera support	Varies
Standard-size table	For scorekeeping, timing, and audio/visual needs; may be reused for awards	1 or more
Chairs	For scorekeeping, timing, and audio/visual needs	1 or 2 per table

**SUPPLIES AND EQUIPMENT – OTHER CONSIDERATIONS/NICE-TO-HAVE ITEMS**

**ROBOT GAME**

- Referee shirts or sports pinnies
- Spare parts
- Measuring stick to verify robot height
- Tape measure to verify longer distances
- Vacuum or duster
- Table skirts
- Ample seating for spectators: *Can the audience see the action? Can you keep spectators out of the competition area?*
- Designated spaces for the scorekeeper, time keeper, and audio/visual support

**SCOREKEEPING**

- Projector and screen
- Video camera
- Timer (if needed)
- Additional tables and tablecloths

**AUDIENCE COMFORT/CROWD CONTROL**

- Audio system
- Audience seating
- Stanchions, cones, pipe, and drapes

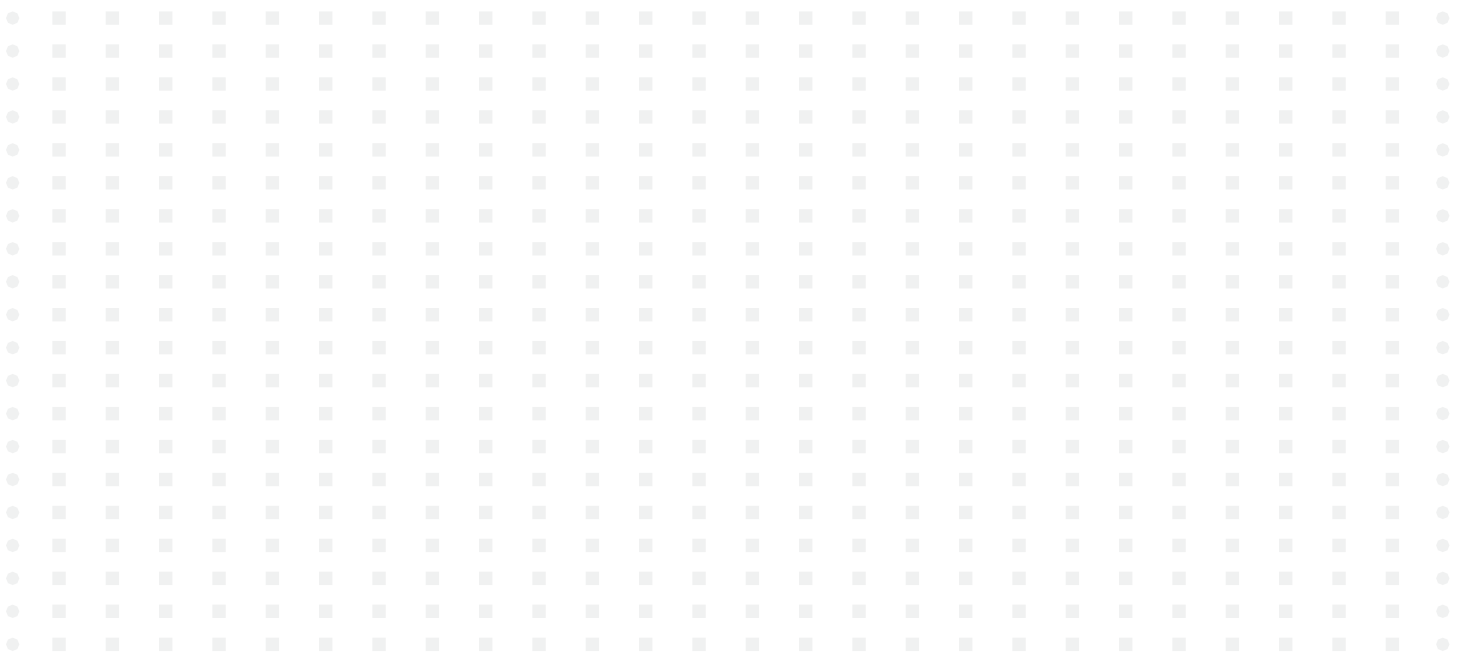

### 3. Judging Pod Area 🌟

Table and chairs for judges

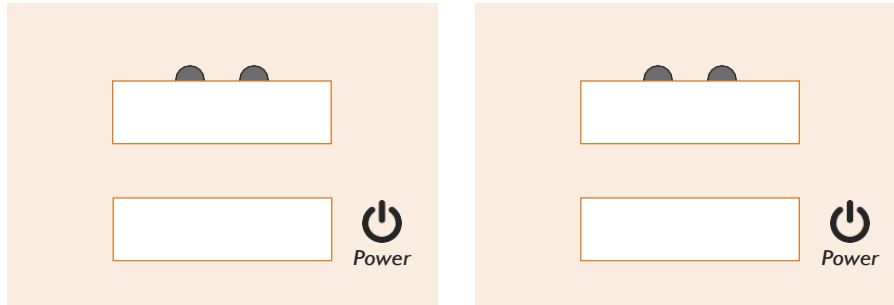

#### SUPPLIES AND EQUIPMENT

##### CONSIDER THE FOLLOWING FOR EACH JUDGING POD

A table teams can use in their Innovation Project presentation and Robot Design explanation

An extension cord and power strip

Chairs for all team members (maximum of 10 team members and two coaches)

Chairs for spectators, if allowed

### 4. Judge Deliberation Room 🌟

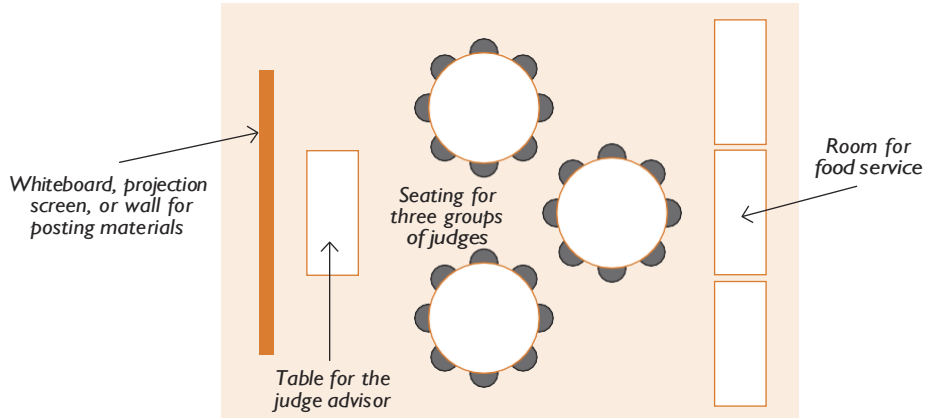

#### SUPPLIES AND EQUIPMENT

##### CONSIDER THE FOLLOWING FOR THIS AREA

A projector and screen

An extension cord and power strip

Tip: Keep refreshments in the area for your volunteers

## 5. Team Pit Area

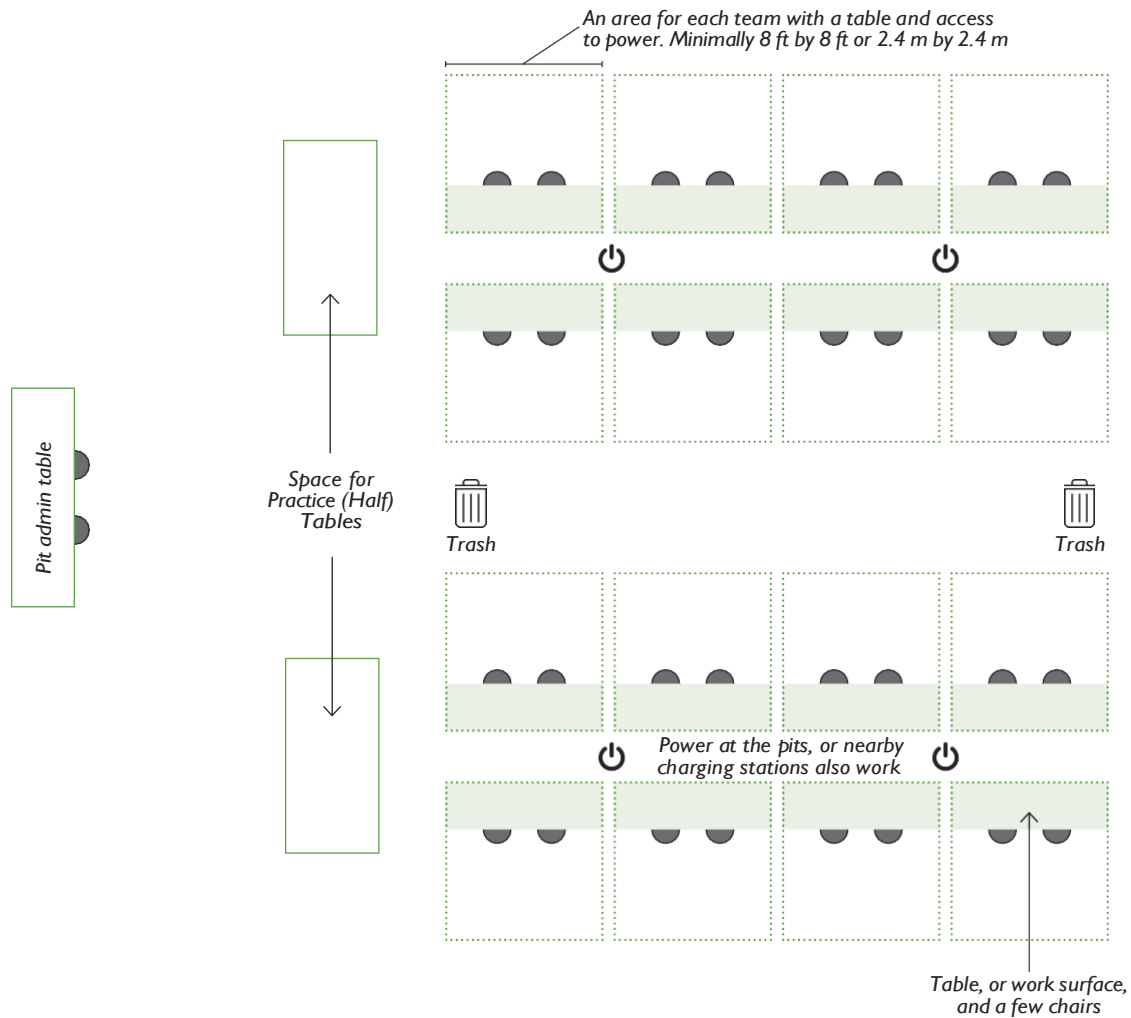

### SUPPLIES AND EQUIPMENT

#### CONSIDER THE FOLLOWING FOR TEAM INFORMATION UPDATES AND VOLUNTEERS WORKING IN THIS AREA

Large, open space with good traffic flow

Pit tables and chairs for teams

Space for practice tables (usually one table per 6-8 teams)

Access to electricity

Extra tournament documents

Audio system for announcements

If food will be sold or if outside food will be permitted

Tip: Keep refreshments in the area for your volunteers



## 6. Referee and Event-Day Volunteer Room 🌟

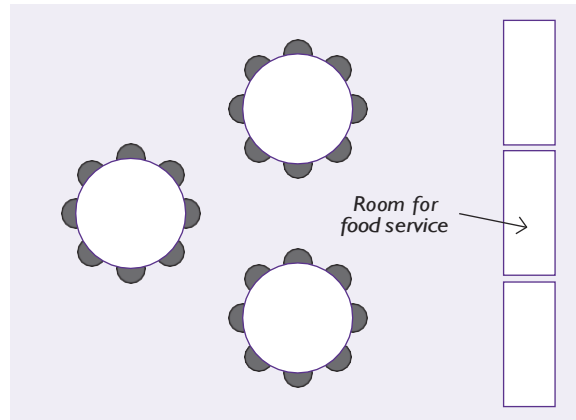

### SUPPLIES AND EQUIPMENT

#### CONSIDER THE FOLLOWING:

Secure, monitored space

Large classroom, meeting room, or cafeteria

Seating for all event-day volunteers

Room to accommodate food service

Space for coats and personal items

## 7. Welcome/Team Check-In/Volunteer Check-In Area 🌟

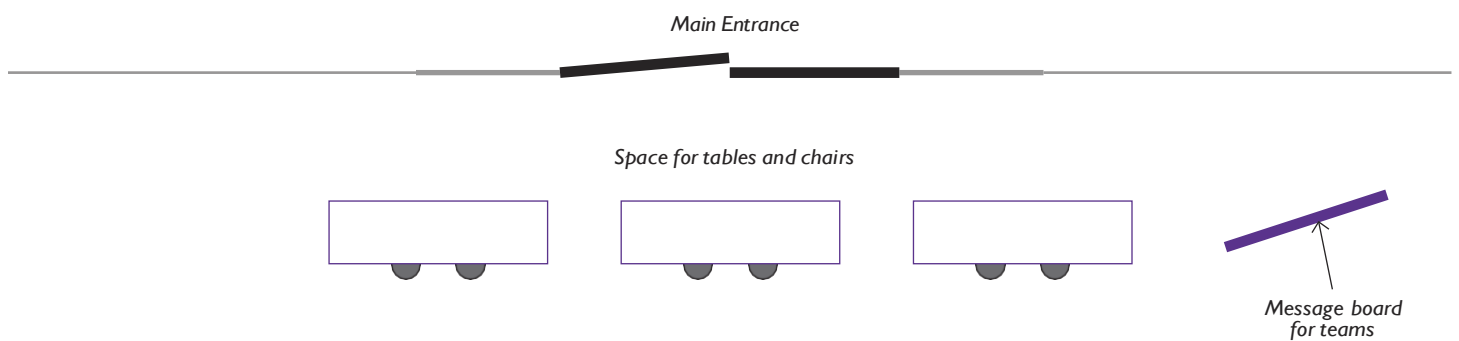

### SUPPLIES AND EQUIPMENT

#### CONSIDER THE FOLLOWING:

Near the entrance

Easy to find

High visibility

Room for several tables



## OTHER SITE CONSIDERATIONS

**Access Times.** When will you need access to the site for event setup and teardown? Make sure your site contact and/or contract confirms. This is especially critical for setup. Make sure your access to the venue provides ample time for setup.

**A/V Support.** What is available in-house and at what cost?

**Contract.** Does the venue owner require that you sign a contract? Who will sign?

**Custodial.** Will you need custodial services during the event? Talk to the venue contact.

**Emergency Services/Procedures.** Does this venue require a trained first-aid person to be on-site? Are there space capacity limits that might affect your plans? ([Additional information is provided in Chapter 9.](#))

**Exterior Signage.** Does the venue have multiple entrances? Do teams and spectators have different entrances?

**Lunch for Teams and Volunteers.** Decide if there will be food for teams to purchase. Is there a designated place for teams and spectators to eat? Volunteer lunches should be provided at no or low cost.

**Parking.** Where will teams, guests, and volunteers park? Is there ample parking?

**Security Personnel.** Does the venue require security personnel for your event?

**Team Traffic Flow.** Will it be easy for teams to get from one area to another?

**Venue Insurance.** Many venues require insurance that covers the event.

## SPACE SUMMARY

Use the following table to see the recommended numbers of judging pods and Robot Game competition tables that you will need for your event.

NUMBER OF TEAMS	MINIMUM NUMBER OF JUDGING PODS	MINIMUM NUMBER OF COMPETITION TABLES
6	1	2
7-12	2	2
13-18	3	2 or 4*
19-24	4	2 or 4*
25-30	5	4 or 6*
31-36	6	4 or 6*
37-42	7	6 or 8*
43-48	8	6 or 8*
49-54	9	8 or 10*
55-60	10	8 or 10*
61-66	11	10 or 12*
67-72	12	10 or 12*

\*Depending on the time available for your event.

## Preparation Timeline

### EARLY KEY DECISIONS

Eight to 12 months before the event:

- Reserve and confirm your venue's date and location.
- Write your budget.
- Know your venue costs.
- Develop a fundraising plan and begin to implement it.

Four to six months before the event:

- Identify your judge advisor.
- Identify your head referee.
- Identify your volunteer coordinator.
- Create your [Volunteer Information Packet](#).



### SETTING UP BEFORE THE TOURNAMENT

#### Robot Competition Area

Typically led by the technical advisor, head referee, and/or field manager:

- Unpack Referee, Robot Competition, Staging Area, and general supply boxes.
- Set up the tournament tables and fields.
- Attach signs to tournament tables.
- Set up the staging area for the robot competition rounds (chairs, signage, barriers, etc.).
- Hang flags, banners, and other signage.
- Set up and test audio, video, and electrical.
- Set up and test scoring station and timer.
- Cover all wiring with tape.
- Set up crowd control for competition.
- Unpack and prepare trophies and medals.

#### Judge Deliberation Room and Judging Pods

Typically led by the judge advisor:

- Unpack Judging Area supply box.
- Set up food tables.
- Lay out supplies (pens, paper, clipboards, markers for whiteboard, etc.).
- Lay out judging rubrics, judge prep packs, programs, team list, schedules, venue maps, etc.
- Lay out judge shirts, if applicable.
- Set up computer for judging pods, if applicable.
- Hang any signage.



## Ceremonies Area

If the Robot Competition Area also serves as the Ceremonies Area, much of it will already be set up.

Typically led by the tournament director if Ceremonies Area is in its own space:

- Set up and test audio.
- Set up podium, if applicable.
- Set up and test video, if applicable.
- Review team flow during the opening and closing ceremonies.

## Referee and Event-Day Volunteer Room

Typically led by the volunteer coordinator:

- Unpack Volunteer Room supply box.
- Set up food and beverage tables.
- Set up coat rack.
- Hang any signage.

## Team Pit Area

Typically led by the pit admin and/or teams coordinator:

- Unpack Pit Area supply box.
- Set up team tables with team signs.
- Set up practice tables with Fields.
- Set up and test announcement system, if applicable.
- Set up pit admin tables and chairs.
- Lay out electrical distribution and cover all wiring with tape.
- Place emergency procedure folder at pit admin table, if applicable.
- Set up trash cans.
- Hang any signage.

## Welcome/Team Check-In/Volunteer Check-In Area

Typically lead by the volunteer coordinator:

- Unpack Team Registration and Welcome Area supply box.
- Set up registration and welcome tables and table covers.
- Lay out schedules, programs, team lists, team registration packets, etc.
- Lay out sponsor, host site or *FIRST* literature.
- Lay out info on local restaurants.
- Lay out volunteer shirts.
- Hang any signage.
- Set up any exterior signage.

## Team Lunch and Refreshment Area

Set up:

- Tables and chairs
- Trash cans
- Signage
- Tables for selling food, if applicable

## Budget

### THE BUDGET

Develop your budget early.

For a typical tournament, the largest costs tend to be:

- Awards/medals
- Food for volunteers
- Venue costs
- Volunteer shirts

A sample budget can be found at this [link](#).

Involve your *FIRST LEGO* League partner in budget development.

- Adhere to any requirements set by your partner.
- Especially for qualifying tournaments, your partner should tell you what he/she will provide and what you are required to provide.



### Venue

Your venue costs can range from nothing (if all is donated or in-kind) to your largest budget item.

Have a clear understanding of your venue costs.

- Venue rental/charges for room usage
- Charges for audio and/or video equipment and staffing
- Custodial fees
- Security fees
- Other charges

### EXAMPLES OF COMMON BUDGET ITEMS

#### REUSABLE

- Competition tables
- Signage
- Referee shirts
- Timers
- Extension cords
- Clipboards
- First-aid kits

#### CONSUMABLES

- Challenge sets
- Trophies
- Food for volunteers
- Printing
- Volunteer identification
- Team recognition
- Gaffer's tape

#### EQUIPMENT, FEES, IN-KIND, AND/OR BORROW

- Audio
- Video
- Venue-usage fees
- Printers
- Rentals, such as tables/chairs
- Computers
- General supplies

## Teams and Communications

### CHECK-IN PACKETS

The *FIRST* LEGO League Challenge Team Information Packet can be found [at this link](#). These are prepared for teams to pick up at team check-in.

### WHAT TEAMS RECEIVE AFTER THE EVENT

Teams should leave your tournament with the following:

- 🏆 Awards: per *FIRST* LEGO League Global Program Standards
  - Not every team will receive one – check with your partner for the awards that will be distributed at your tournament.
- 🏆 Advancements: per *FIRST* LEGO League Global Program Standards
  - Only a percentage of teams will advance – check with your partner for the percentage of teams that will advance from your tournament.
- 📄 Rubric Feedback Sheets: every team should receive their rubric feedback sheets.
- 🏆 Team Recognition: individual certificates, ribbons, key chains, medals, or other
  - A form of recognition such as medals or certificates must be provided for all participants at championships
  - 🌟 If possible, every team member should receive recognition at a qualifying event.
  - 🌟 A high-five line is encouraged for distribution of this recognition.

### GENERAL DATA PROTECTION REGULATION (GDPR)

Remember, if you collect any personal data from event participants, you must follow the [FIRST Privacy Policy](#). Personal data could include paper copies of the *FIRST* Consent and Release Form; team rosters; and coach, mentor, or volunteer contact information. Here are a few tips to keep personal data safe:

- Treat all personal data with the utmost confidentiality and security.
- Limit data use and availability to only those who need it to perform a specific role at the event.
- Never share personal data with anyone outside of the event.
- If sharing is required among personnel working the event, always use secure file transfer methods such as Microsoft OneDrive, Microsoft Teams, or encrypted email.
- Confirm that the data is private and not publicly accessible.
- Always ensure that digital data is kept in password-protected files.
- Delete any downloads of the data immediately at the conclusion of use. Make sure you delete the file from your downloads folder and trash/recycle bin.
- Destroy hard copies of files or forms containing personal data using methods such as shredding.

Contact [privacy@firstinspires.org](mailto:privacy@firstinspires.org) or the *FIRST* IT help desk at [helpdesk@firstinspires.org](mailto:helpdesk@firstinspires.org) if you have questions.



## Scheduling

### PREPARING A SCHEDULE

Before you start to prepare your schedule, there are a few things you need to consider first. Every event is different, and the schedule for the event should be tailored to suit the needs of your teams and the physical aspects of the venue. The following list should be used to guide you through the process of creating your own custom schedule.

#### Resources

How many teams are participating at your event? This will have an impact on the amount of resources and time you will need; for example, how many judging pods and Robot Game competition tables will be needed. The following information will help with these decisions.

#### JUDGING PODS

The new name for a judging room is a judging pod. This is helpful for remote or hybrid events where there may not be a physical room in which teams and judges meet. There is now only one judging session, which covers Core Values, the Innovation Project, and Robot Design. These sessions take 30 minutes with the team and then a further 10 minutes after the team has left for the judges to complete and submit the rubrics.

It is recommended that a maximum of six teams are seen per judging pod. This will take 240 minutes (four hours).

#### ROBOT GAME COMPETITION TABLES

For each tournament setup, two competition tables, each with its own mat and set of LEGO mission models, are fixed together as shown in this diagram. Teams should not compete on tables that are not joined in this way.

This shows two competition tables. A referee is needed at each table, so two referees are needed here.

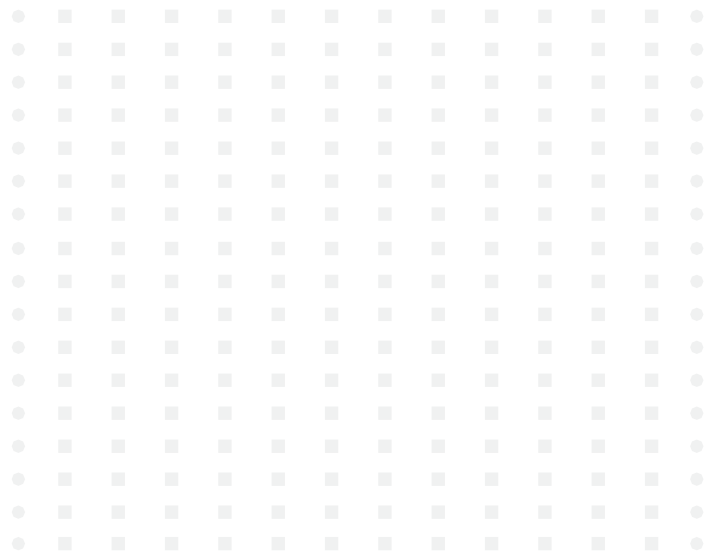
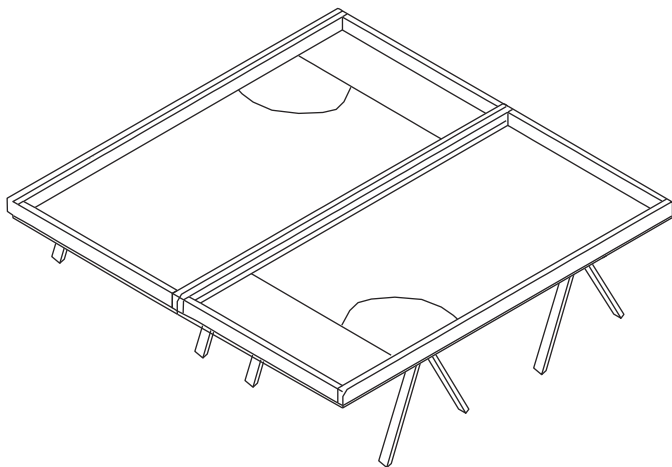

---

## Timing

- What time do you want the event to start? Take into account the distance the teams would have to travel to get to your venue. Think about what time you want the Robot Games and judging to start, and then work back to get your arrival and registration time.
- What time do you want the event to finish? Don't forget you will need to include an awards ceremony. Sometimes it helps to work back from when you want to be finished.
- Would you like the judging sessions and Robot Games to span the whole day, or would you prefer all judging sessions in the morning with the Robot Games in the afternoon or vice versa?
- Do you want to schedule any practice Robot Game rounds for the teams?
- Are you going to schedule any breaks or lunch? If so, how long? What time works best?
- Are you going to schedule anything else, such as an opening ceremony or team photos? If so, how long will they be, and what time works best?

**WHEN YOU HAVE ALL THIS INFORMATION, YOU CAN START DECIDING HOW YOU WILL SCHEDULE YOUR EVENT.**

### Tips on Scheduling

- Remember: Each judging pod should see a maximum of six teams in four hours. How many pods of judges will you need to ensure all components of the event are completed? If you are struggling to make it all fit, think about increasing the number of judging pods or lengthening/shortening aspects of the day where you have some flexibility. [Refer to the Space Summary chart in Chapter 3.](#)
- Also think about how many Robot Competition Areas you will need. There is flexibility around how quickly your referees can process teams at the Robot Game competition tables. Often there is a 10-minute slot, which includes 2.5 minutes for the team to set up, 2.5 minutes for the Robot Game, 2.5 minutes for scoring, and 2.5 minutes for resetting the table.
- This would mean that in one hour, you would have time for six Robot Game matches (six 10-minute slots). Therefore, on two competition tables, this would be 12 teams competing in one Robot Game each. Don't forget that each team needs a minimum of three Robot Game matches, so you need to also consider how many competition tables you have to work with. [Refer to the Space Summary chart in Chapter 3.](#)
- Now that you have thought about these questions, you can start to build up your schedule for the day. Feel free to scale the numbers up or down to suit the size of your tournament. Do not worry, it might take a couple of drafts to get everything on the schedule with the correct time and resource. Make sure you re-read these questions once you have completed your schedule to double-check that you haven't missed anything. Good luck!

FIRST has provided a simple schedule generator and templates available in two 12-team versions. These can be found [at this link](#).

[For more detailed information, refer to Chapter 3.](#)

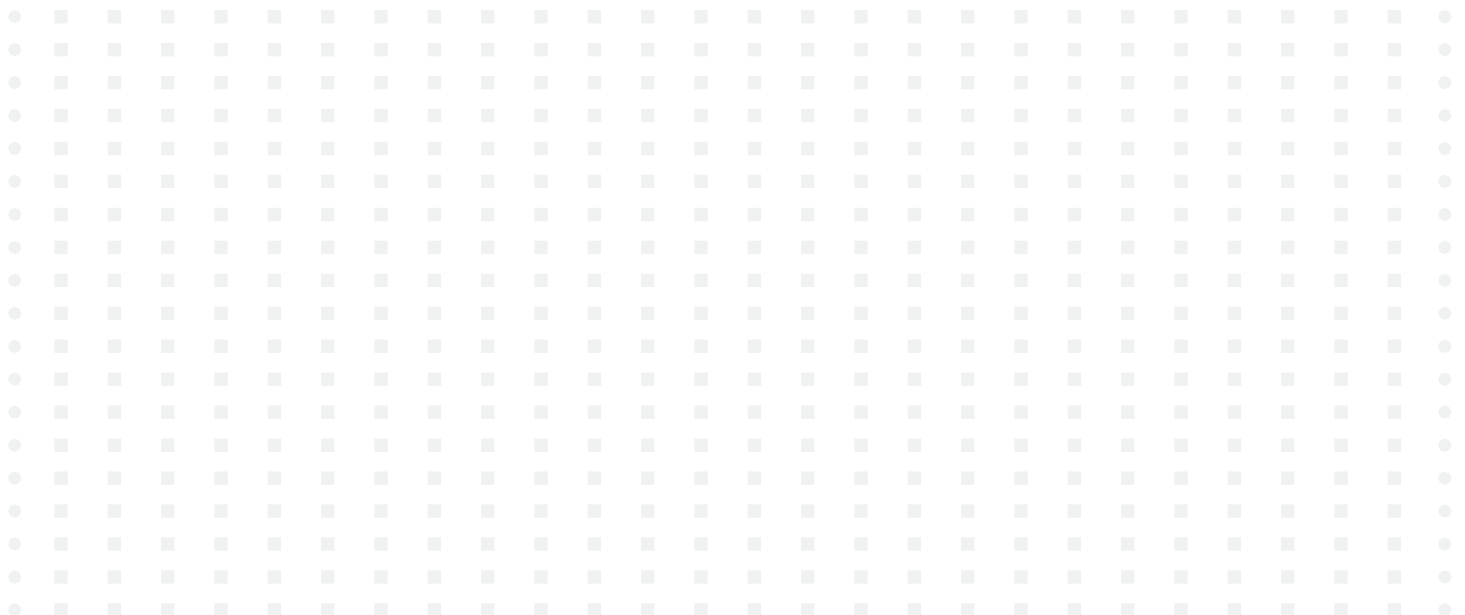

## Documents and Signage

### DOCUMENTATION

Prepare for your tournament by producing or borrowing the following:

- Tournament documents
- *FIRST*-branded materials
- Sponsor banners/signs/displays
- Exterior parking and directional signs
- Large interior signs
- Small room or small area signage
- Program book



### SPONSOR RECOGNITION

There are many ways to recognize sponsors at your event.

Make sure you honor the recognition requirements promised for sponsors that donate an agreed-upon price point.

Options include:

- Sponsor name and logo on signs and banners
- Sponsor name and logo projected on the screen during ceremonies
- Sponsor name and logo scrolling on the scoring software

Sponsor name and logo should be provided by the PDP.

### PARKING AND ENTRANCE SIGNAGE

- Parking and other outside directional signs identify your venue as the tournament site and directs your volunteers, teams, and spectators to designated parking and entry points.
- Welcome signs at the entrance (inside and outside the building) confirm to people that they are in the right place.

### AREA SIGNAGE

- Identify your tournament areas with signs that can be placed on easels or taped to walls (with venue permission).





## Event Safety, Accessibility, and Cancellation

### EMERGENCY AND EVACUATION PLANS

The planning team should know the emergency and evacuation procedures at their venue ahead of time.

It is recommended that an emergency folder listing these procedures and protocols be created for members of the planning team and key volunteers, such as the pit admin and field managers.

What would you do in case of the following?

- A lost child
- Tornado
- Fire
- Loss of power
- Earthquake
- Snow or ice storm
- Medical emergency
- Tsunami
- Violent person



### SAFETY

- Work with your venue's contact to understand any relevant building or fire codes, any safety and health requirements or regulations, as well as any local and applicable laws.
- Be mindful to tape down or hide cords and wires. Gaffer's tape is excellent for this job. Always check with your venue before applying tape to floors.
- Be aware of room capacity limits.
- Do a walkthrough of your venue looking for trip hazards, especially in high-traffic areas.
- Be careful not to block exits.
- Make sure paths remain clear and open.
- Determine if you are required to hire security or medical personnel.



---

## INCIDENTS

- With your venue’s contact, review the venue’s procedure should an attendee get hurt.
- If there is immediate danger, injury, or risk of injury – call emergency services immediately. (For example, in the US, call 911.)
- If there is a significant incident, the *FIRST* LEGO League PDP should be contacted immediately after you contact emergency services.
- 🌐 Should there be an incident, a completed incident report form should be given to the appropriate Field Operation Manager/Partner Services Manager at either LEGO or *FIRST*.
- There are two types of incidents that need to be reported – medical and non-medical. Report forms can be found on the [Youth Protection Program page](#). Instructions are included on the forms. Several copies should be printed and made available.
- Review the incident report forms ahead of time.



## ACCESSIBILITY

- Your venue should meet all accessibility requirements or regulations.
- Inform teams in advance of any limitations as to accessibility. For example, let them know if the venue does not have a ramp to the ceremony stage.
- Ask coaches if any of their students have special needs and what accommodations will be requested. Ask your volunteers the same.



## CANCELLATION POLICY

- No one likes to think about the possibility of cancellation. However, plan ahead. The safety of the teams is most important.
- Before considering canceling the event, pivot to a remote event.
- Know in advance the answer to this question: Under what conditions will you have to cancel your event?



Work with your PDP to create a comprehensive cancellation policy that includes the reasons for cancellation, methods by which all parties will be notified, and whether the event will be rescheduled. Communicate this policy in advance of the tournament date. If you know the event will not be able to be rescheduled, share how teams will advance and/or what happens to any fees collected as soon as possible.

See the [FIRST Youth Protection Program](#) for more information.

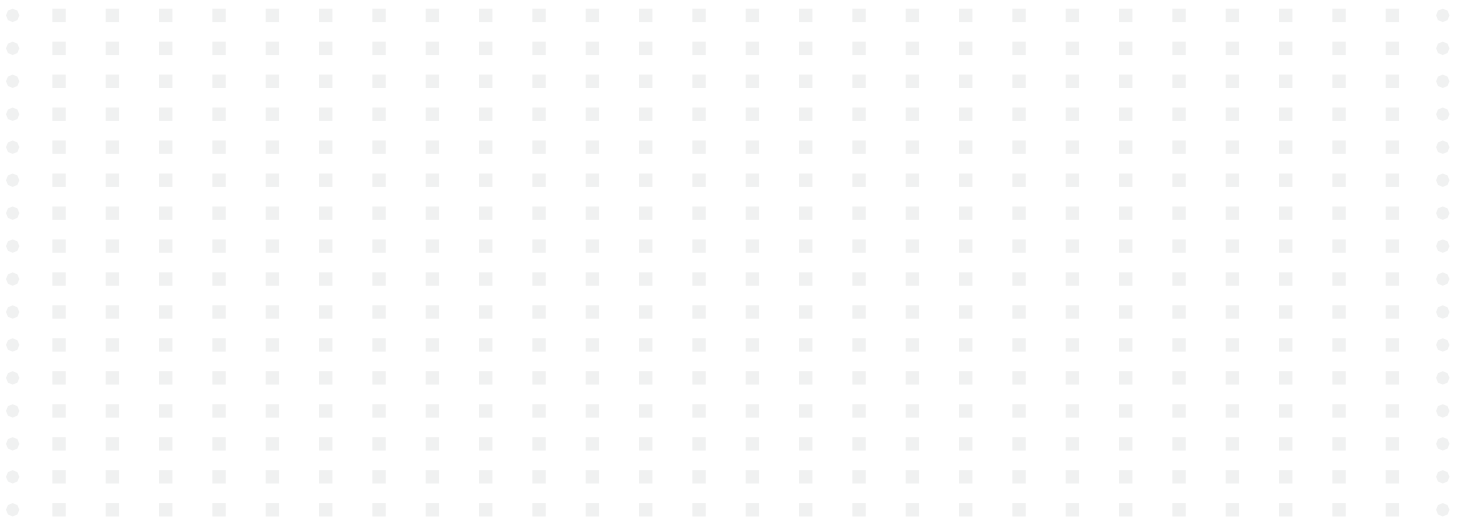

## Production

### PRODUCTION OVERVIEW

#### Purpose of Production

- Include the audience in the experience of the ceremonies and game play.
- Enhance the team experience.

#### Two Production Parts

- Robot Game, managed by the field manager
- Ceremonies, managed by the production coordinator

#### Elements

- Audio – music, guest speakers, announcers
- Video – produced by *FIRST* for ceremonies
- Video cameras – Robot Game
- Video cameras – emcee and guest speakers
- Displays – scores and game clock

### PRODUCTION: ROBOT GAME

#### Field Manager

Responsible for:

- Music
- Play-by-play audio
- Scores displays
- Video cameras
- Game clock
- It is the job of the field manager to make sure that the Robot Game is delivered as scheduled and the audio and visual components are working as planned.
- The field manager should work with the technical advisor for all audio, visual, and software support.



## PRODUCTION: ROBOT GAME TECHNICAL ELEMENTS

### Field Manager with Technical Advisor

Responsible for:

- Computers – scoring, music, video
- Video cameras – Robot Game (one or two video cameras)
- Screens – one for scores, one for other visuals
- Projectors – one for each screen (one or two)
- Sound system – speakers, microphones for emcees and making announcements

## PRODUCTION: ROBOT GAME WITHOUT CAMERAS

Consider your space:

- Can people view the Robot Game from an atrium area?
- Can you set up the competition tables as close to seating as possible?



## PRODUCTION: CEREMONIES

### Production Coordinator

#### RECOMMENDED ELEMENTS

Tip: *FIRST* provides script templates for each season to use for awards ceremonies.

#### Opening Ceremonies

- Parade of teams (optional)
- National anthem of host country (per local protocol)
- Guest speaker (Innovation Project expert, host, or sponsor)
- *FIRST*-produced video(s)
- Recognition and thanks to volunteers, host site, and sponsors

#### Closing Ceremonies

- Medal or certificate distribution via high-fives line
- Event slideshow (optional)
- Volunteer appreciations and award
- Sponsor recognitions
- Awards distributions

#### CEREMONIES: PRODUCTION COORDINATOR

Works with tournament director to:

- Deliver ceremonies within a set time.
- Write scripts (templates available).
- Create or locate video and audio content.
  - *FIRST* videos
  - National anthem (per local protocol)
  - Music
  - Team slideshow
- Identify, invite, greet, and provide seating for performers, guest speakers, sponsors, and other dignitaries.
- Produce the ceremonies at the event.

Works with technical advisor to:

- Provide audio support for presenters (wireless/hands-free microphones), video, and music.
- Provide visual support –computers, video cameras, screens, projectors, video player, and slideshow creation.
- Provide adequate lighting for Robot Game tables and cameras.
- Safely secure cables and cords.
- Provide volunteers to assist with technical support for camera operators and A/V or DJ





### Opening/Closing Ceremony Rehearsal

- Rehearse the entire ceremony. You may be unable to practice some elements, such as the parade of teams or guest speaker presentations. Estimate the time it will take for these pieces and use stand-in volunteers when possible.
- The emcee reads the script aloud and confirms pronunciations.
- The A/V operator practices incorporating video components into the ceremony.
- The technical advisor runs a sound check with the systems and sets sound levels.
- The production coordinator confirms the pattern for parade of teams and team seating (if incorporated) as well as determines who will assist with this flow.
- Determine where the camera operators will stand. Consider good camera angles for guest speakers (the back of their head is a poor angle, for instance).
- If a national anthem will be performed live, practice the performer's entrance and exit with them.
- Time the ceremony – will it run on schedule?

Note: Often guest speaker(s) will not be able to join the rehearsal. Make sure you give that person a time limit and offer to prepare some remarks or talking points for them.





## Judging Overview

### JUDGING STANDARDS AND GUIDELINES

Please use these guidelines to implement judging at your event.

TOPIC	STANDARD	BEST PRACTICE
Training	<ul style="list-style-type: none"> <li>Judging at all official events is led by a judge advisor.</li> <li>All judges at official events are trained.</li> <li>All training should be delivered using the resources in the Judging Toolkit.</li> </ul>	
Judges	All teams are evaluated by a minimum of two judges.	A judging pod should see no more than six teams a day.
Rubrics	The <i>FIRST</i> LEGO League <a href="#">rubrics</a> must be used at all official events in their complete, original form and may be altered only for translation.	
Judging Session	<ul style="list-style-type: none"> <li>All judging sessions follow the “Session Flowchart for Judges” in the Judging Toolkit.</li> <li>Each judging session should allow 30 minutes per team for evaluation.</li> <li>Additional time may be given at the judge advisor’s discretion for teams with special circumstances, such as team members with special needs or if translation is needed.</li> <li>10 minutes should be allocated for judges to complete and submit rubrics after each team has left the session.</li> </ul>	15 minutes can be allocated for judges to complete and submit rubrics after each team has left the session.
Core Values	All judges should be familiar with the six <a href="#">FIRST Core Values</a> , which will be evaluated throughout the judging session.	
Awards	<ul style="list-style-type: none"> <li>Awards must be given according to the “Awards and Allocation” document, which can be found in the Judging Toolkit <a href="#">at this link</a>.</li> <li>Except for the Robot Game Award and the Coach/Mentor Award, teams may win only one award.</li> <li>Ensure that 30-50 percent of teams receive awards.</li> </ul>	
Deliberations		Use the Official Judging Spreadsheet as a tool to present area ranks and aid deliberation and award allocations.
Award Eligibility	Only teams as stated in the <i>FIRST</i> LEGO League Team Participation Rules are eligible for awards.	
Advancement	The Champion’s Rank should be used to identify teams who are advancing to the next level of the competition.	
Release of Judging Information	<ul style="list-style-type: none"> <li>The complete list of all judging evaluations for every team should remain confidential, along with any information regarding ranking of teams.</li> <li>Rubric-based feedback should be provided to each team, either at the end of the event or within a reasonable time following the event.</li> </ul>	

---

## JUDGING ROLES

[See role descriptions on page 2.](#)

Additional qualifications and experience/training needed are as follows.

### Judge Advisor

#### QUALIFICATIONS

- Outgoing personality with gravitas to lead judge deliberations in an inclusive, timely manner to give judges confidence in their decisions
- Detailed knowledge of the Official Judging Spreadsheet and *FIRST* LEGO League Challenge awards allocation needed for their specific events and the *FIRST* LEGO League Challenge advancement policy
- Strong leadership and mentorship skills
- Strong interpersonal/communication skills
- Strong organizational skills
- Ability to collaborate with others and work as a team
- Ability to lead an entire judging team to consensus on award recipients

#### EXPERIENCE/TRAINING NEEDED

This is a KEY volunteer position. KEY volunteers require advanced training as prescribed by *FIRST* headquarters.

- *FIRST* LEGO League Challenge experience essential
- *FIRST* LEGO League Challenge judge advisor training required

### Lead Judge

#### QUALIFICATIONS

- Strong assessment skills in grading according to a rubric and facilitating open-ended questions
- Strong interpersonal/communication skills
- Ability to effectively relate to youth aged 9-14 and adults as well as be a mentor and role model at all times
- Ability to work as a member of a team and lead that team to consensus
- Knowledge of *FIRST* LEGO League Challenge rubrics, award criteria, and selection process
- *FIRST* and/or *FIRST* LEGO League experience preferred

### Judge

#### QUALIFICATIONS

- Strong assessment skills in grading according to a rubric and facilitating open-ended questions
- Strong interpersonal/communication skills
- Ability to effectively relate to youth aged 9-14 and adults and always be a role model
- Ability to work as a member of a judging pod and in a larger team of judges
- Knowledge of *FIRST* LEGO League Challenge rubrics, award criteria, and selection process

#### EXPERIENCE/TRAINING NEEDED

- New judges required to attend training or be paired with experienced judges

*All judges express the FIRST philosophies of Gracious Professionalism® and Coopertition® through our [Core Values](#). The FIRST Core Values are the cornerstones of all FIRST programs.*

---

## RECRUITMENT TOOLS

Judge advisors can customize the following message to use in judge recruitment:

You don't have to be a rocket scientist to inspire kids!

FIRST LEGO League Challenge is looking for enthusiastic individuals who can offer guidance in a friendly and supportive manner. The philosophy of the competition is that every team member can positively contribute to the success of their team.

We need people who can interact with students to help measure this impact while acting as a mentor to help develop and nurture them on their journey. Your role is to value all the work they have done throughout the season and show them they can succeed no matter how their robot performs.

Measuring performance is important, but for the program to have the most impact, teams need to leave the tournament feeling that they have made progress and, most of all, had FUN!

Qualities we're looking for:

- Good communicator with young people
- Enthusiasm
- Open-mindedness
- Flexibility
- Approachability
- Compassion and empathy
- Willingness to share your professional insights

No previous FIRST LEGO League experience is needed for most roles, and training will be provided.

If you would like the opportunity to shape and grow the next generation of innovators and help to steer them through their STEM journey, then we want to hear from you.

Roles available:

- Judge Advisor
- Lead Judge
- Judge

Please contact your local PDP for more information regarding judging opportunities and other event roles.

## TRAINING TOOLS

We have developed a toolkit to support judge training and communication as well as communication tools for the teams attending your events. This can be found [at this link](#).

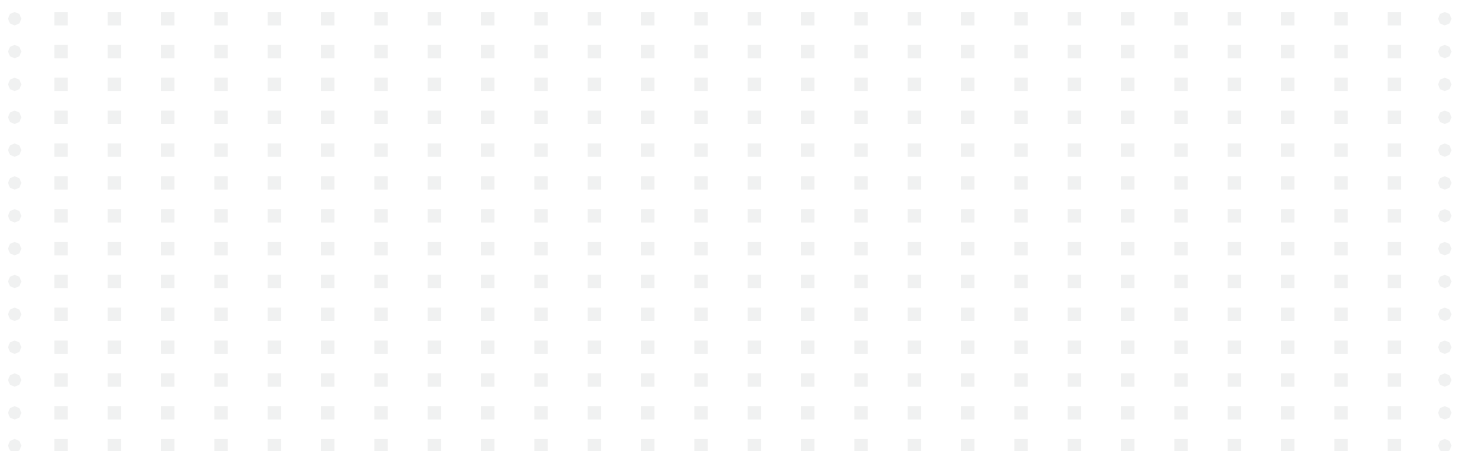

## Robot Game Overview

### REFEREE STANDARDS AND GUIDELINES

Please use these guidelines to referee your event.

TOPIC	STANDARD
Training	<ul style="list-style-type: none"> <li>All referees at official events are trained by the head referee.</li> <li>All training should be delivered using the resources in the Referee Toolkit.</li> </ul>
Game material	The <i>FIRST LEGO League</i> field setup, missions, and rules must be used at all official events in their complete, original form and may be altered only for translation.
Game play	<ul style="list-style-type: none"> <li>All teams must participate in three separate Robot Game matches.</li> <li>Each match is 2.5 minutes and has two teams playing opposite of each other on a tournament setup.</li> <li>At the tournament, only two team members at a time are allowed at the competition table except during repair emergencies. The rest of the team must stay back from the table, but close enough for different members to tag in or out as desired.</li> </ul>
Awards	<ul style="list-style-type: none"> <li>Robot Game scores must be shared with the judge advisor for use in judge deliberations.</li> <li>The Robot Game Award winner is based on the single highest official match score. In the event of a tie, the next highest match scores are used. No other method, such as average or total score, can be used.</li> </ul>

[See role descriptions on page 2.](#)

Additional qualifications and experience/training needed are as follows.

#### Head Referee

##### QUALIFICATIONS

- Advanced knowledge of the competition game and rules of play
- Ability to be tactful and assertive
- Ability to withstand physically demanding role and stand for long periods of time
- Outgoing personality; high energy
- Strong communication and diplomatic skills
- Ability to collaborate with others and work as a team
- Detail oriented
- Strong assessment skills
- FIRST LEGO League* experience and training required

#### Referee

##### QUALIFICATIONS

- Thorough knowledge of the competition game and rules of play
- Ability to be tactful and assertive
- Ability to withstand physically demanding role and stand for long periods of time
- Outgoing personality; high energy
- Strong communication and diplomatic skills
- Ability to collaborate with others and work as a team
- Detail oriented
- Strong assessment skills
- FIRST LEGO League* experience and training required

---

## Scorekeeper

### QUALIFICATIONS

- Basic knowledge of the competition game and rules helpful
- Ability to collaborate with others and work as a team
- Excellent computer skills
- Detail oriented; driven to achieve high level of accuracy

## Field Manager

### QUALIFICATIONS

- Basic knowledge of the competition games, rules, and table setup necessary
- Ability to work as part of a team and be an effective communicator; ability to keep chain of command informed of critical issues and schedule
- Physically active role: ability to stand for long periods of time and move quickly about the field
- Excellent problem-solving skills
- *FIRST* and/or *FIRST* LEGO League experience necessary

## Emcee

### QUALIFICATIONS

- Knowledge of the competition game and rules helpful
- Public speaking skills
- Comfort and experience interacting with youth aged 9-14
- Sense of humor

## TRAINING TOOLS

We have developed a toolkit to support referee training. It can be found [at this link](#).

## ROBOT COMPETITION AREA SETUP

*FIRST* LEGO League recommends at least one tournament setup per 12 teams. Practice rounds, while not required, are strongly encouraged. Work with your head referee to decide if you want to schedule one or more practice rounds. Discuss the referee recruitment plan with your head referee and volunteer coordinator.

As you design your Robot Competition Area layout, account for a buffer zone of at least 6 feet or 1.8 meters around the tournament setups for the competing team members and referees.

Also account for an area next to each set of competition tables where the remaining team members can stand in the buffer zone. It is recommended that you use tape to designate these areas, but get permission from your venue before placing tape on the floor.

Adjacent to the Robot Competition Area should be an area for teams to wait for their upcoming match. This area is often called a staging area, queuing area, or on-deck area.

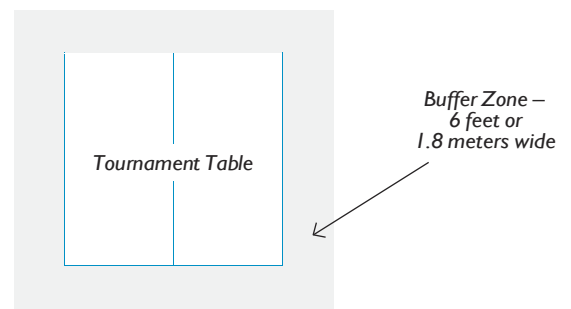



## SUPPLIES AND EQUIPMENT – MUST HAVE ITEMS

ROBOT GAME – MUST HAVE ITEM		
ITEM	DESCRIPTION	QUANTITY
Tournament setup	One tournament setup = two 4' x 8' competition tables together	1 per 12 teams
Table supports: legs, folding tables, saw horses, or milk crates	To support the competition tables (must support six corners for each tournament setup and four corners for each solo practice competition table)	Varies
Wood screws	To hold competition tables together	2 per tournament setup
Challenge sets	Challenge field with mat, LEGO mission models, and extra Dual Lock	2 per tournament setup
Clipboards, scoresheets, and scoring materials	<p>Clipboards: two per tournament setup plus one for head referee and one for emcee.</p> <p>Blank scoresheets: one per practice or official round (at least three) per team (i.e., # Scoresheets = # Teams x # Rounds). It is helpful to have a few extra blank scoresheets.</p> <p>Pens or pencils: at least one per referee</p> <p>Tablets/phones (for electronic scoring): two per tournament setup plus one for head referee; one may be useful for emcee</p>	See description.
Timer/stopwatch	To measure time remaining in each match (can be projected using scoring software or measured at each table by a stopwatch or cell phone timer)	1 overall or 1 per tournament setup
Small signs, if more than one tournament setup	To identify tournament setup for audience and teams (may be letter-size signs or colored table skirts that match the table names on the schedule)	2 per tournament setup

SCOREKEEPING – MUST HAVE ITEM		
ITEM	DESCRIPTION	QUANTITY
Computer	For scoring and audio/visual needs	1 or more
Extension cords and power strips	For scoring, audio/visual, and video camera support	Varies
Standard-size table	For scorekeeping, timing, and audio/visual needs; may be reused for awards	1 or more
Chairs	For scorekeeping, timing, and audio/visual needs	1 or 2 per table

## SUPPLIES AND EQUIPMENT – OTHER CONSIDERATIONS/NICE-TO-HAVE ITEMS

ROBOT GAME	
Referee shirts or sports pinnies	
Spare parts	
Measuring stick – to verify robot height	
Tape measure – to verify longer distances	
Vacuum or duster	
Table skirts	
Designated spaces – for the scorekeeper, time keeper, and audio/visual support	
SCOREKEEPING	
Projector and screen	
Video camera	
Timer (if needed)	
Additional tables and tablecloths	
AUDIENCE COMFORT/CROWD CONTROL	
Audio system	
Ample seating for spectators: <i>Can the audience see the action? Can you keep spectators out of the competition area?</i>	
Stanchions, cones, pipe, and drapes	

## Event Promotion

### AVAILABLE RESOURCE MATERIALS

- Current season graphics can be found [here](#).
- A Public Relations Toolkit can be found [at this link](#).



## Post Event

### SURVEY

- You should ask your teams and volunteers for their feedback. But, check with your partner first for any region-wide effort.
- Free and easy-to-use online services such as SurveyMonkey or Google Forms can be used.
- Possibly include a survey card with each team's rubrics.
- You could also send a simple email asking for the three best things and three things that need improvement.
- Whatever you do, try to keep it simple and short.

### RETURNS

#### What to Return to Your PDP

- Robot Game scores (file)
- List of award winners
- Any completed walk-on volunteer forms
- Any incident report forms
- (Qualifiers only) List of teams advancing to the championship event
- (US/CAN only) Team rosters, with any paper consent forms, collected at team check-in
- If applicable, completed Official Judging Spreadsheet (OJS) Excel file

#### What to Return to Teams

- Judging rubrics if they were not returned at the event

### THANK YOUR SPONSORS

Follow up with your donors and sponsors, as promised. Believe it or not, they want to hear from you. This is considered good stewardship.

- Consider any one or all of the following:
- Send pictures from the tournament.
- Send them team stories, including local teams that moved on to a World Festival, Open Championship, or Global Innovation Award consideration.
- Have teams at the event sign a big thank-you card; then, send them the card.
- Send a post-event report.
- Send a program booklet, especially if your sponsors are recognized in it.

